

Series 25, 26, 27

Features

- Snap fits into panel cutout
- Incandescent and neon illumination
- Single or dual lenses
- Dummy (hole plugs) available

Specifications

- Body Material: Nylon
- Lens Material: Polycarbonate
- Wire Gauge: 18 ga.
- Terminals: .250 Tabs, Solder Lugs
- Panel Thickness: .020 to .250
- Certifications: Contact Us

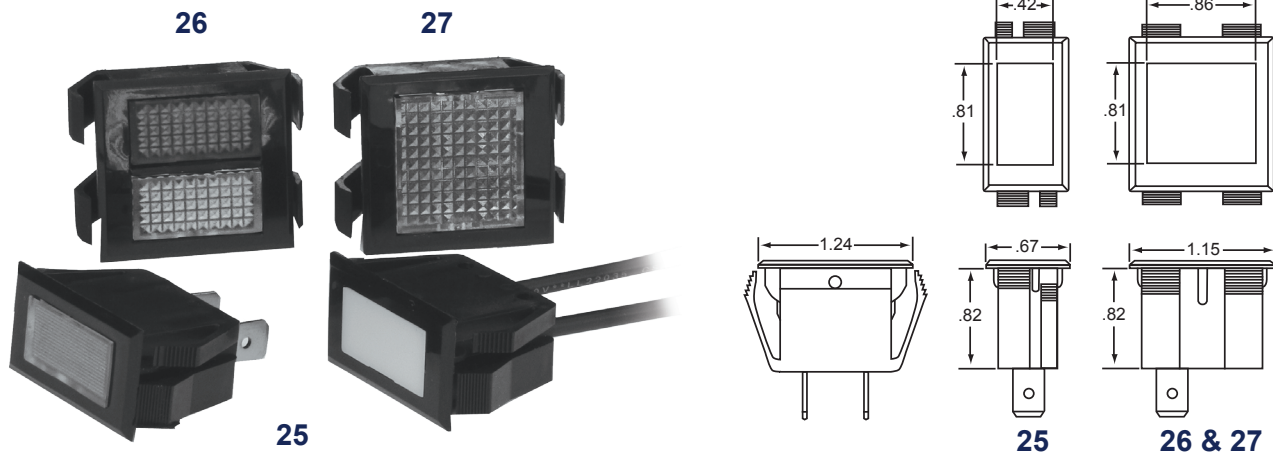

Series	Lamp			Termination		Base		Bezel		Lens			
XX	XX			X		X		X		XXX			
	Voltage	Type	Code	Style	Code	Color	Code	Finish	Code	Style	Code	Color	Plain
25	N/A	DUMMY	00	N/A	0	Matte White	4	None	0	Rectangular Translucent	451	Red	1
26	6	INCAND	32	6" Wire	1	Matte Black	5	Stainless ¹	1	Rectangular Diamond	453	Amber	2
27	14	INCAND	35	.250 Tabs	4			Black ¹	3	Rectangular Line	455	Clear	3
	28	INCAND	39	Solder	5					Square Translucent	461	Green	4
	125	NEON	50	Special	X					Square Diamond	463	Blue	5
	250	NEON	52							Square Lines	465	White	6
		Special	XX									Black	7

Panel Cutout Series 25

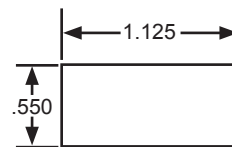

Panel Cutout Series 26 & 27

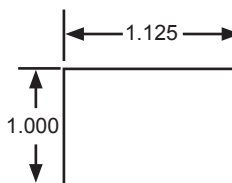

Color	Marked
Red	A
Amber	B
Clear	C
Green	D
Blue	E
White	F

Series	Code
25 & 27	0
26	Select 2nd lens color

White is Translucent
Clear is Transparent

Additional Options Available:
Contact Factory

1. Series 25 and 26 only

Rectangular Indicators